

User's Manual

M Series Monitor



www.altoproaudio.com
Version 1.3 October 2005

— English —

SAFETY INSTRUCTIONS



▲ "Electric discharge"

This symbol, alert you to the presence of uninsulated dangerous voltage inside the product enclosure, which constitutes a risk of electric shock.

▲ "Exclamatory point"

This symbol, alert the user to the presence of important operating and maintenance instructions in the owner's manual included to the product.



Disposing of this product should not be placed in municipal waste and should be Separate collection.

1. Read Instructions

All the safety and operation instructions should be read before using the product and retain them for future reference.

2. Water & Moisture

This product should not be used near water and will be protect from atmospheric agents in fixed or temporary installations.

3. Heat

This product should be situated away from heat sources such as radiators, or other devices which produce heat.

4. Liquid Entry

Care should be taken so that liquids are not spilled into the product and that objects do not fall on.

5. Service Assistance

This product should be serviced only by qualified service personnel when :

- a. Liquids has spilled or objects have fallen into this product, or
- b. This product has been exposed to rain, or
- c. This product does not appear to operate normally or exhibits change in performance, or has been dropped or its cabinet / chassis damaged.

6. Package

The package of this product has been tested, inspect the package before open, if any damage is found, notify to your dealer.

7. Hearing

This product produce high acoustic levels may cause permanent hearing loss, (SPL in for a defined period of time).

8. Installations

This product should be installed on the floor with a specific stand, according to the max weight, or in suspension with a five points included in the cabinet (M10 × 1.5PH Length 30mm).

The suspension of more speaker cabinet in a vertical array is NOT advised.

PANEL CONTROLS

- For M Series Passive Monitor Speakers

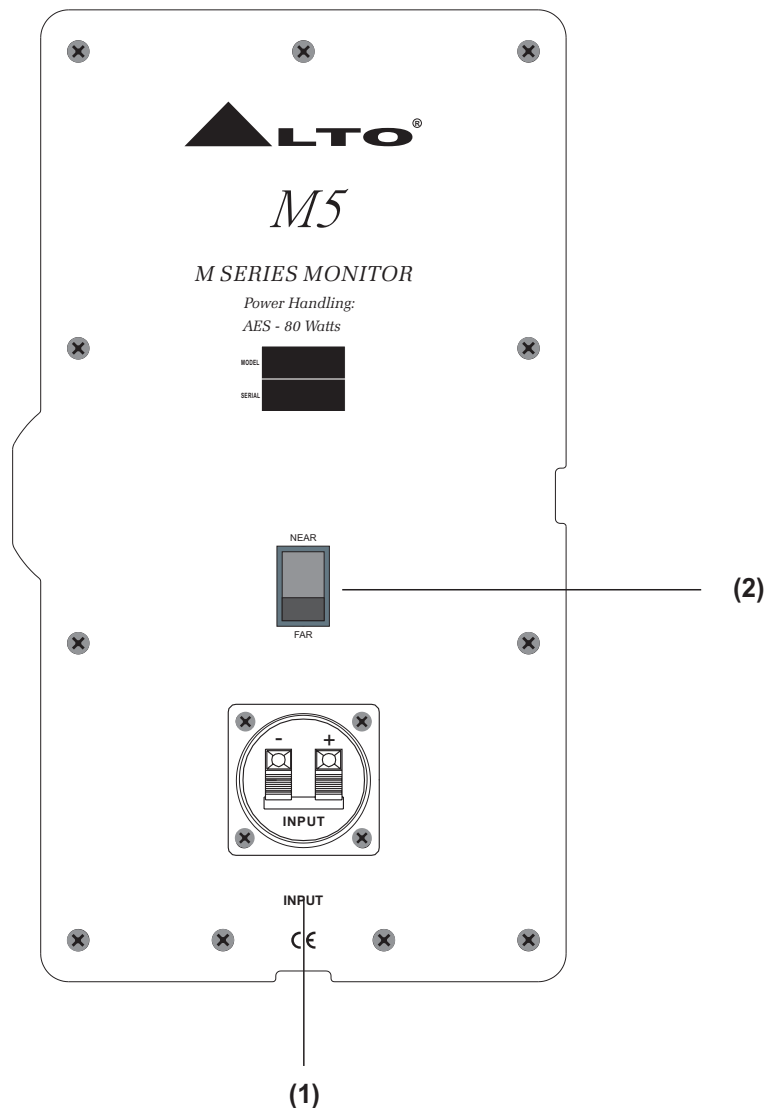

(1) Input Connector

This professional 2P screw terminal speaker jack is used to input the amplified high level program sources coming from the external power amplifier.

Caution: Pay more attention to the connection of the speaker cables, only the speaker cable + terminal to amplifier + output, and the speaker cable - terminal to amplifier - output.

Detail connecting information, please refer to the " WIRE CONNECTIONS".

(2) NEAR or FAR field selection

Via this switch, you can apply your M series monitor speakers in the near field or far field configuration.

Generally, near field option is designed for the near distance monitor which is mainly used in the smaller sound system, and the speakers are placed relatively close to the listener, normally about 1~1.5m.

By the near field monitoring, you can try to avoid the interference caused by the acoustic environment, esp. the reverb effect, and do the serious mixing.

As for far field option, it is usually designed for the larger sound systems, where the monitor speakers are placed comparative farther away from the listener.

- For M Series Active Monitor Speakers

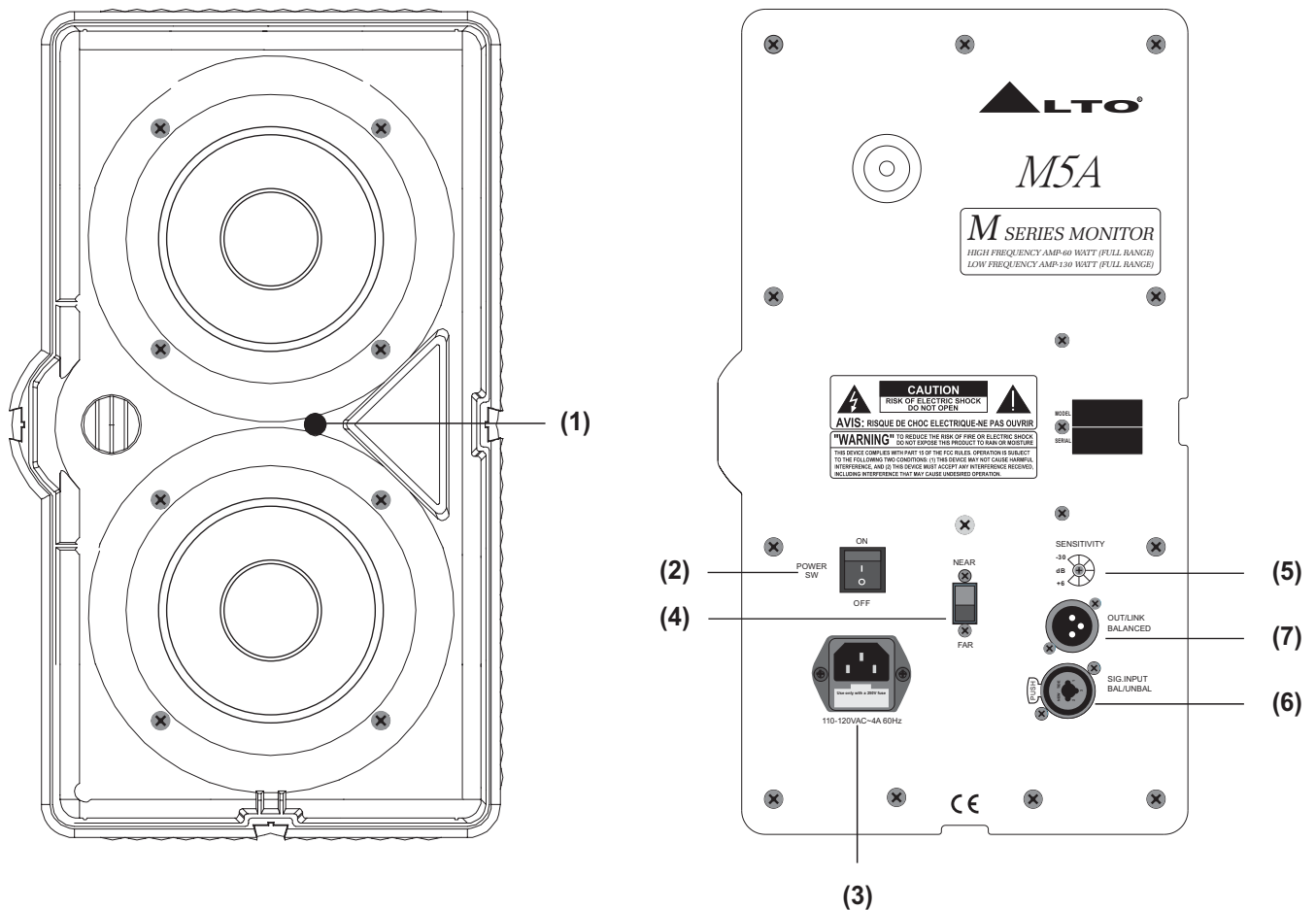

(1) Power Indicator

This LED lights up blue when the M series active speakers are powered on.

(2) Power Switch

This switch is used to turn the M series active speakers on or off.

Caution: Make sure your supply voltage is identical to the value marking on your products before turning on the power switch.

(3) AC Socket with Main Fuse

This socket is used to connect your M series active monitor speakers with the mains.

Caution: Before turn on the power, please make sure the voltage is identical to the values marking on the products. Fuse replacement should be done by qualified personnel only, and only with same value fuse.

(4) NEAR or FAR Field Selection

Via this switch, you can apply your M series monitor speakers in the near field or far field configuration.

Generally, near field option is designed for the near distance monitor which is mainly used in the smaller sound system, and the speakers are placed relatively close to the listener, normally about 1~1.5m.

By the near field monitoring, you can try to avoid the interference caused by the acoustic environment, esp. the reverb effect, and do the serious mixing.

As for far field option, it is usually designed for the larger sound systems, where the monitor speakers are placed comparative farther away from the listener.

(5) SENSITIVITY Control

Adjust this trim pot to get the proper input gain.

(6) SIGNAL INPUT

This combined connector is used to input the program sources either in balanced or unbalanced configuration.

(7) OUT/LINK

This balanced XLR connector is linked in parallel with the SIGNAL INPUT, and it can be used to output the input signal directly.

WIRE CONNECTIONS

- For M Series Passive Monitor Speakers

In ▲LTO M series passive monitor speakers, the professional 2P screw terminal speaker jack is provided to input the amplified high level program sources, normally, it can withstand the high transient voltage and give you the reliable and effective cable connection.

But, here, we strongly recommend you to pay more attention to its electrical connection with the power amplifier, and avoid any polarity mismatch issue.

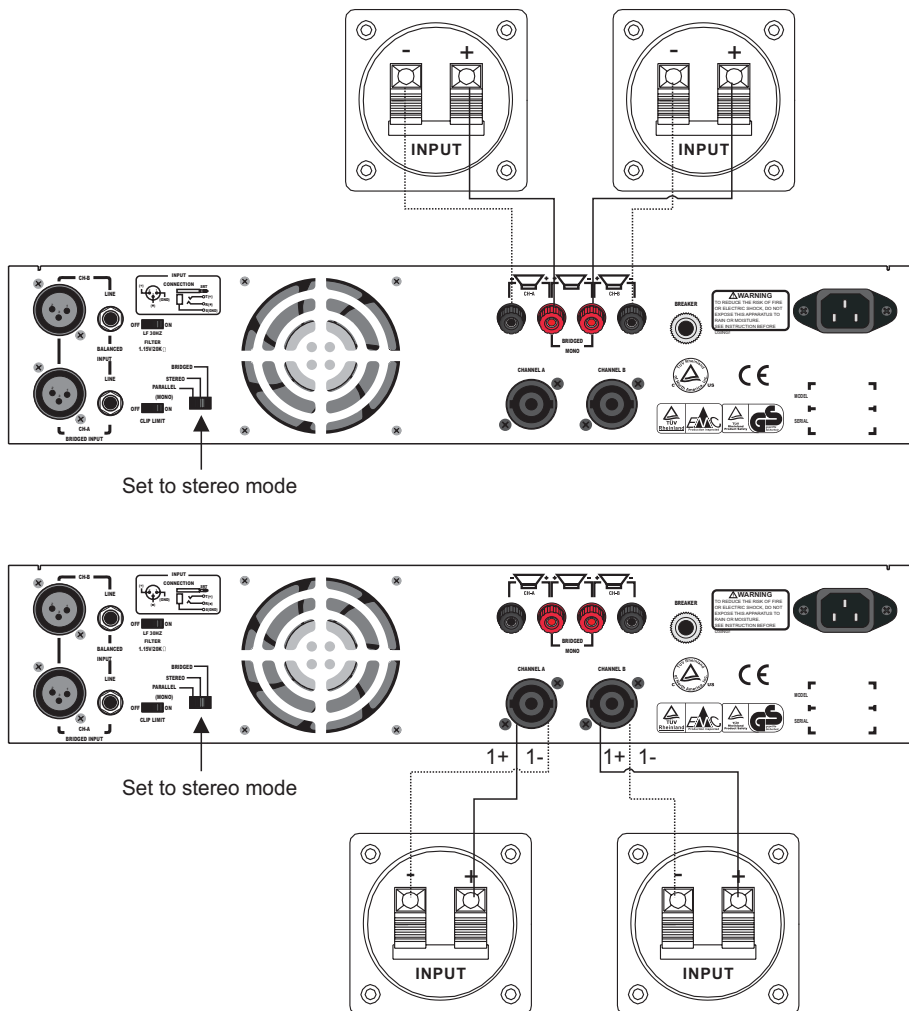

Caution: Before turn on the power of the amplifier, please make all initial connections for your M series passive monitor speakers first.

- For M Series Active Monitor Speakers

As to ▲LTO M series active monitor speakers, just like most of the traditional amplifiers in the market, we should consider its audio connections intended for the low level signal flow, either in the balanced or the unbalanced connection.

• Balanced connection

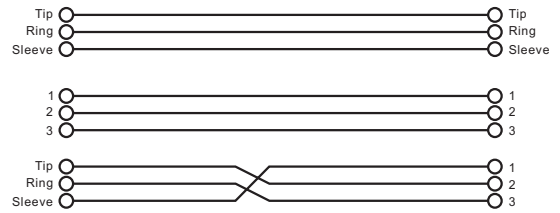
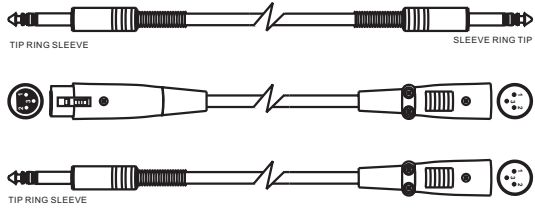

• Unbalanced connection

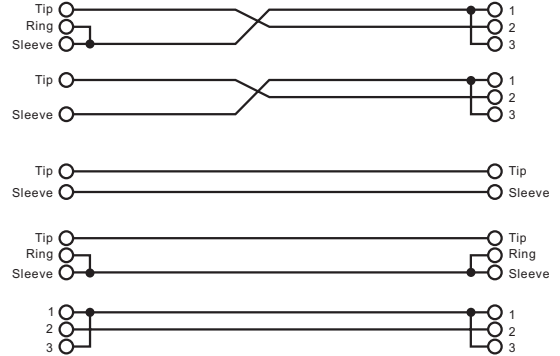
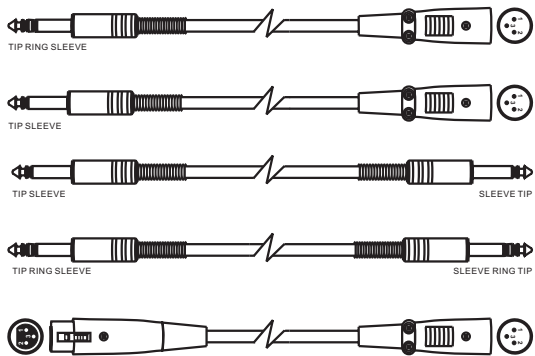

INSTALLATION

Since you have had your own monitor speakers, how to install them into your audio environment, place them on a shelf, or mount them on the wall? The M series monitor speakers give you the versatile choices.

For wall mounting application, we strongly suggest you to use the optional wall mount kit manufactured by ALTO.

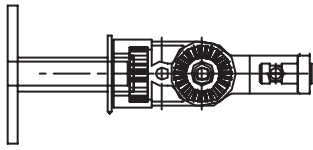

Side View

Accessory (optional): YS-60

Adjustable angle wall mount bracket

Detail information on how to install it, please refer to the appendix.

Installation steps:

1. Mount the base (4) on the wall.
2. Adjust the angle of the bracket according to the acoustic environment.
3. Push the Solid Slide (12) into the specific Slot of the monitor speakers.
The M series monitor speakers provide 3 slots for each unit, please choose the most reasonable one to install.
4. Use two screws (11, M3×10) to stop the Solid Slide at the proper position in the Slot.
5. Insert the Connecting Lever (10) of the accessory into its Fixing Lever (8), then use another screw (9, M6×1.0PH×10) to fasten them.
6. It is done, now, you have got the best installation.

Caution: While mounting the monitor speaker on the wall, please ensure the wall is strong enough to support it.
Consult the installation specialist or the dealer for further instruction.

Installation examples:

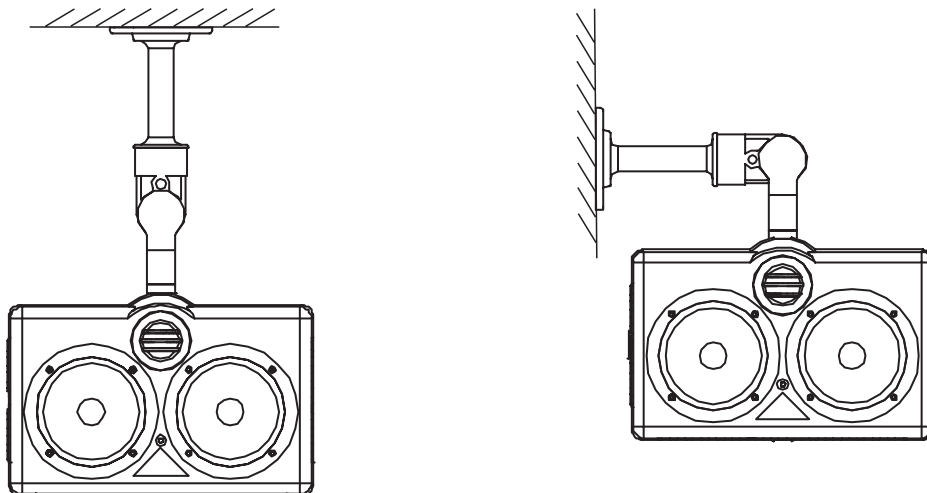

APPENDIX

Exploded Diagram of The Accessory (YS-60)

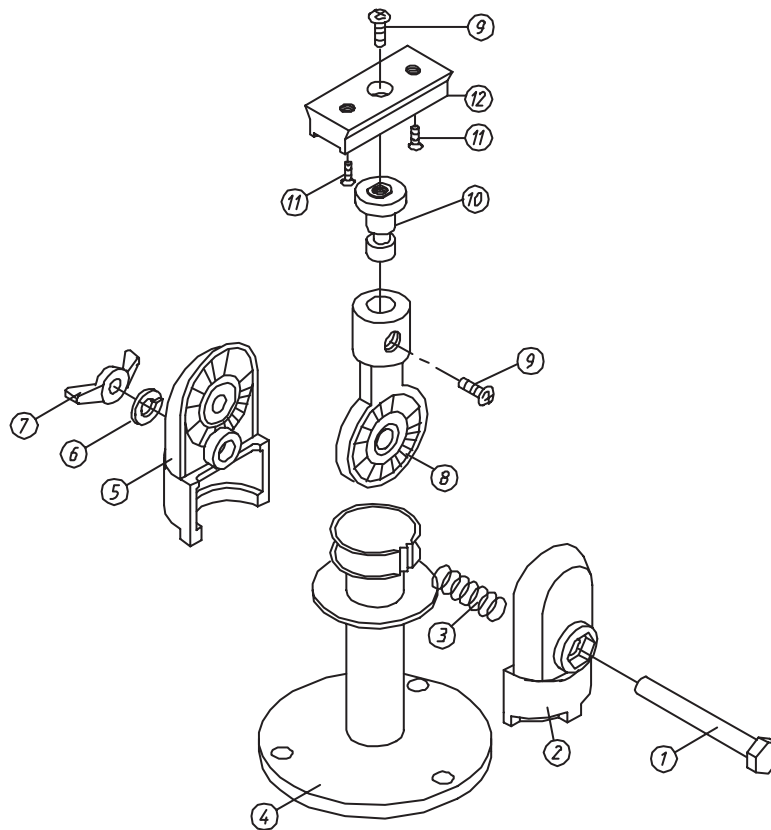

Item	Part Description
1	Ni Screw, M6×55×1.0PH
2	Fixing Bracket - Left
3	Spring
4	Mounting Base
5	Fixing bracket - Right
6	Spring Washer
7	Ni Nut
8	Fixing Lever
9	Zn Screw, M6×1.0PH×10
10	Connecting Lever
11	Ni Screw, M3×10
12	Solid Slide

TECHNICAL SPECIFICATIONS

	M3	M4	M5
System type	2 Way	2 Way	2 Way
Power Handling	AES 30W	AES 70W	AES 80W
SPL 1W, 1m	87dB	92dB	95dB
Frequency Response	50Hz-13kHz (-10dB)	40Hz-15kHz (-10dB)	40Hz-15kHz (-10dB)
Impedance	4Ohm	4Ohm	4Ohm
Crossover Frequency	2.3-3kHz (at 1m/W)	2.3-3kHz (at 1m/W)	2.3-3kHz (at 1m/W)
Dimension HxWxD	216.5x143.5x152.5mm	287.5x169x201mm	376x223.5x267mm
Net Weight /kg	2.4kg	4.8kg	6.6kg

	M3A	M4A	M5A
System type	2 Way	2 Way	2 Way
Power Handling : HF	20W(EIAJ), 15W(RMS)	36W(EIAJ), 30W(RMS)	70W(EIAJ), 60W(RMS)
LF	38W(EIAJ), 30W(RMS)	72W(EIAJ), 60W(RMS)	142W(EIAJ), 130W(RMS)
SPL 1W, 1m	87dB	92dB	95dB
Frequency Response	50Hz-13kHz (-10dB)	40Hz-15kHz (-10dB)	40Hz-15kHz (-10dB)
Impedance	4Ohm	4Ohm	4Ohm
Crossover Frequency	2.3-3kHz (at 1m/W)	2.3-3kHz (at 1m/W)	2.3-3kHz (at 1m/W)
Dimension HxWxD	216.5x143.5x152.5mm	287.5x169x201mm	376x223.5x267mm
Net Weight /kg	3.6kg	6.5kg	8.3kg

SEIKAKU TECHNICAL GROUP LIMITED
No. 1, Lane 17, Sec. 2, Han Shi West Road, Taichung 40151, Taiwan
<http://www.altoproaudio.com> Tel: 886-4-22313737
email: alto@altoproaudio.com Fax: 886-4-22346757

All rights reserved to ALTO. All features and content might be changed without prior notice. Any photocopy, translation, or reproduction of part of this manual without written permission is forbidden. Copyright © 2005 SEIKAKU GROUP